



# LIN 2.1 / SAEJ2602-2, LIN Physical Layer

## MC33662

Last Updated: Jan 25, 2023

The NXP® MC33662 is a physical layer component dedicated to automotive LIN sub-bus applications.

- Designed to support automotive networks with Controller Area Network (CAN)
- Part number selection defines the operating baud rate (33662L or 33662S for 20 kB/s and 33662J for 10 kB/s)
- Both integrate a fast baud rate (100 kB/s) for test and programming modes
- Provides excellent Electromagnetic Compatibility (EMC) and Radiated Emission performance, Electrostatic Discharge (ESD) robustness and safe behaviour in case of TXD short to ground

## MC33662\_BD Block Diagram

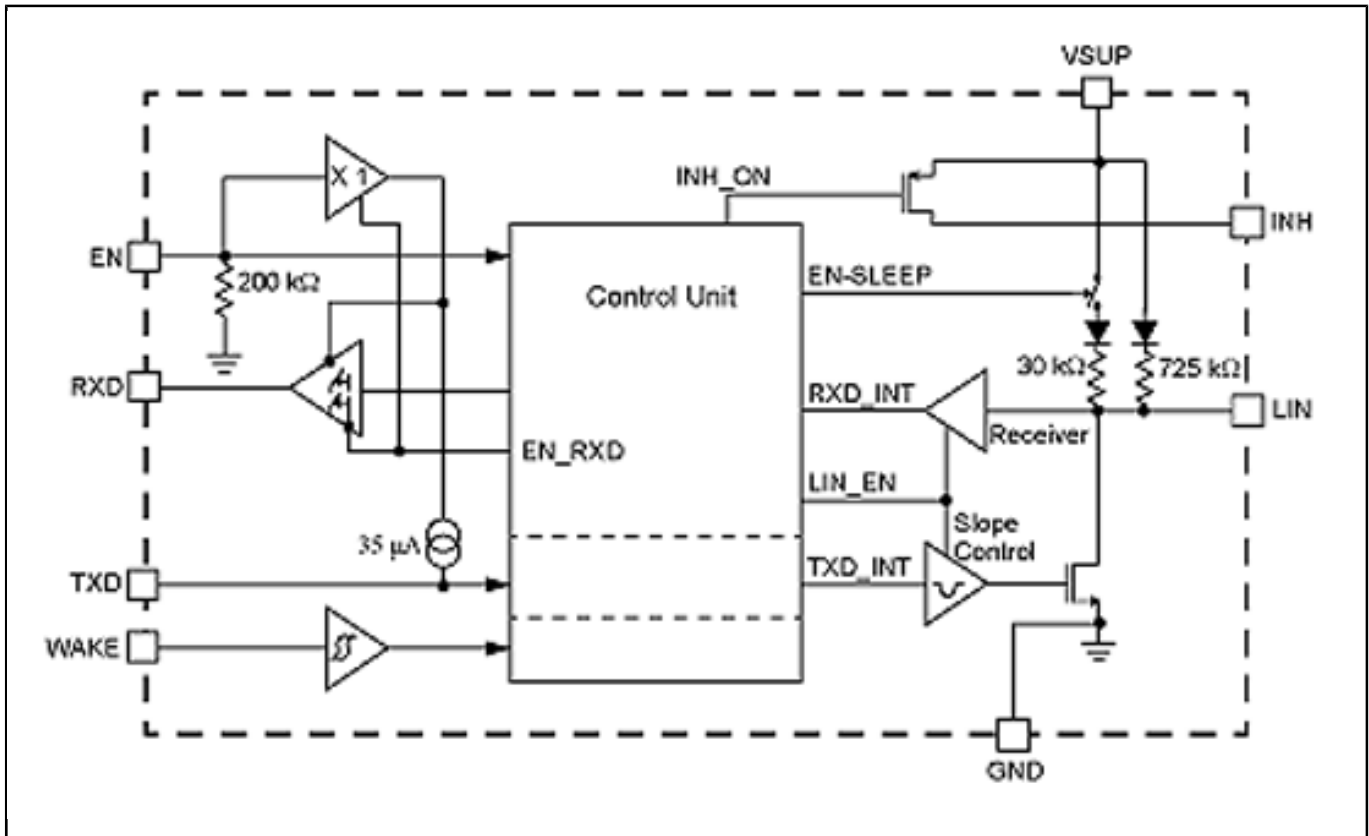

View additional information for [LIN 2.1 / SAEJ2602-2, LIN Physical Layer](#).

Note: The information on this document is subject to change without notice.

[www.nxp.com](http://www.nxp.com)

NXP and the NXP logo are trademarks of NXP B.V. All other product or service names are the property of their respective owners. The related technology may be protected by any or all of patents, copyrights, designs and trade secrets. All rights reserved. © 2023 NXP B.V.