



Automotive Multi-Coil Wireless Charging Transmitter

RDWCT-15WTXAUTO

Last Updated: Nov 15, 2022

The NXP® 15 W multi-coil transmitter reference platform is designed for automotive wireless charging applications based on the NXP MWCT1013AVLH transmit controller IC.

The controller IC manages and performs all control functions necessary to implement a wireless charging transmitter solution. It provides high-performance wireless charging system while taking the complex operating environment of a vehicle into consideration.

[WCT-15WTXAUTO Qi® Wireless Charging Transmitter Solution - Fact Sheet](#)

Automotive Multi-Coil Wireless Block Diagram

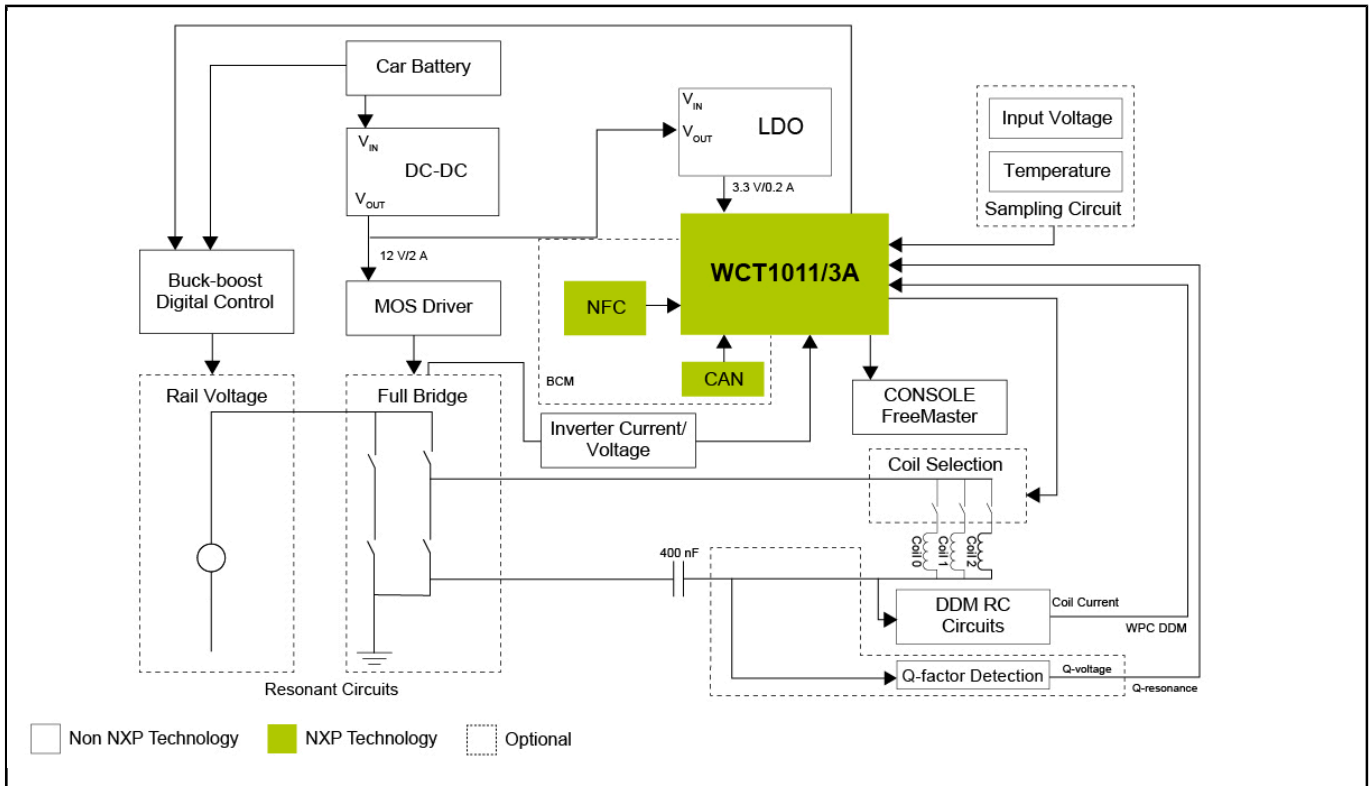

View additional information for [Automotive Multi-Coil Wireless Charging Transmitter](#).

Note: The information on this document is subject to change without notice.

www.nxp.com

NXP and the NXP logo are trademarks of NXP B.V. All other product or service names are the property of their respective owners. The related technology may be protected by any or all of patents, copyrights, designs and trade secrets. All rights reserved. © 2022 NXP B.V.