



# Dual LIN 2.2A/SAE J2602 Transceiver

## TJA1022

Last Updated: Apr 8, 2022

The TJA1022 is a dual LIN transceiver that provides the interface between a Local Interconnect Network (LIN) leader/follower protocol controller and the physical bus in a LIN network. It is primarily intended for in-vehicle subnetworks using baud rates up to 20 kBd and is compliant with LIN 2.0, LIN 2.1, LIN 2.2, LIN 2.2A and SAE J2602. The TJA1022 is pin compatible with the TJA1020, TJA1021 and TJA1027. The TJA1022 and TJA1027 are also software compatible.

The transmit data streams generated by the protocol controller are converted by the TJA1022 into optimized bus signals shaped to minimize ElectroMagnetic Emissions (EME). The LIN bus output pins are pulled HIGH via internal termination resistors. For a leader application, an external resistor in series with a diode should be connected between pin VBAT and each of the LIN pins. The receivers detect receive data streams on the LIN bus input pins and transfer them via pins RXD1 and RXD2 to the microcontroller.

Power consumption is very low when both transceivers are in Sleep mode. However, the TJA1022 can still be woken up via pins LIN1/LIN2 and SLP1\_N/SLP2\_N.

## TJA1022 Block Diagram Block Diagram

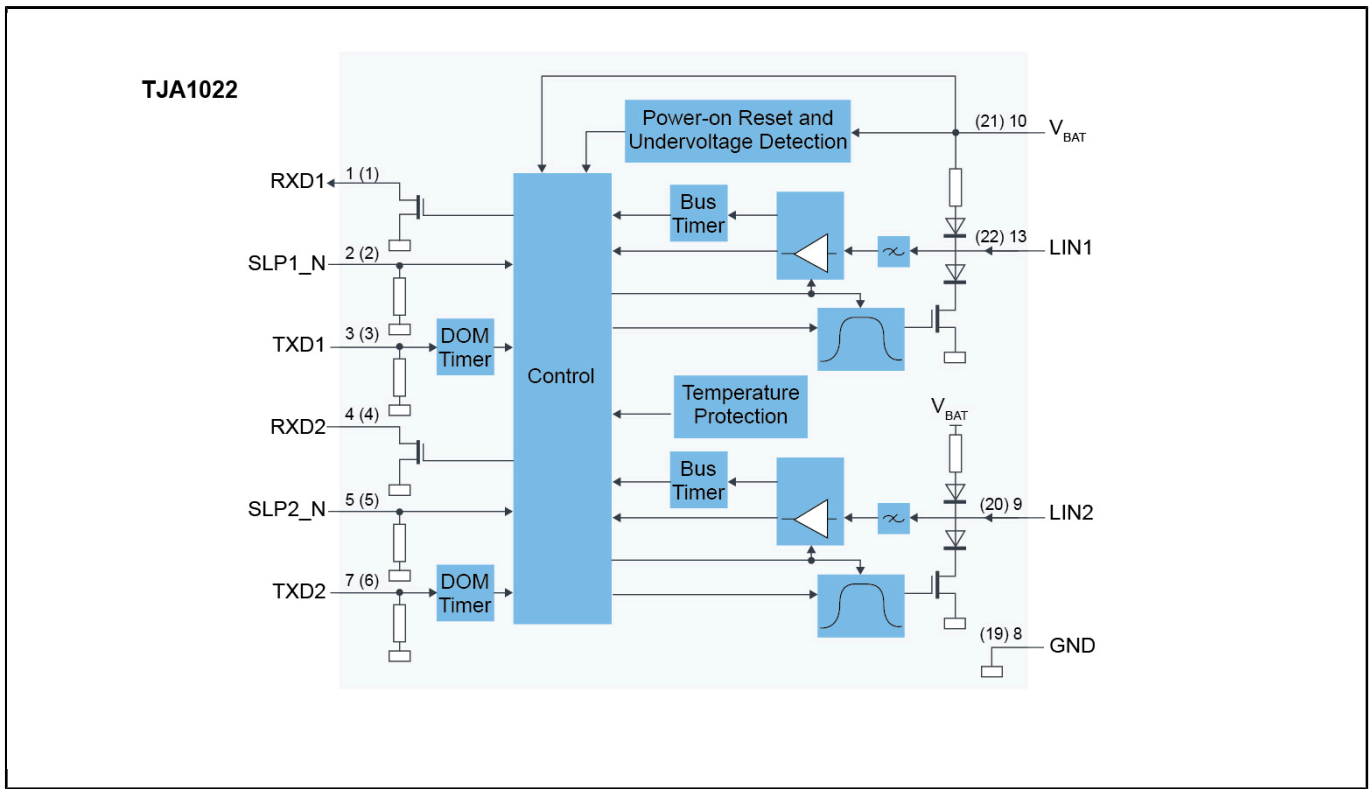

## TJA1022 Block Diagram Block Diagram

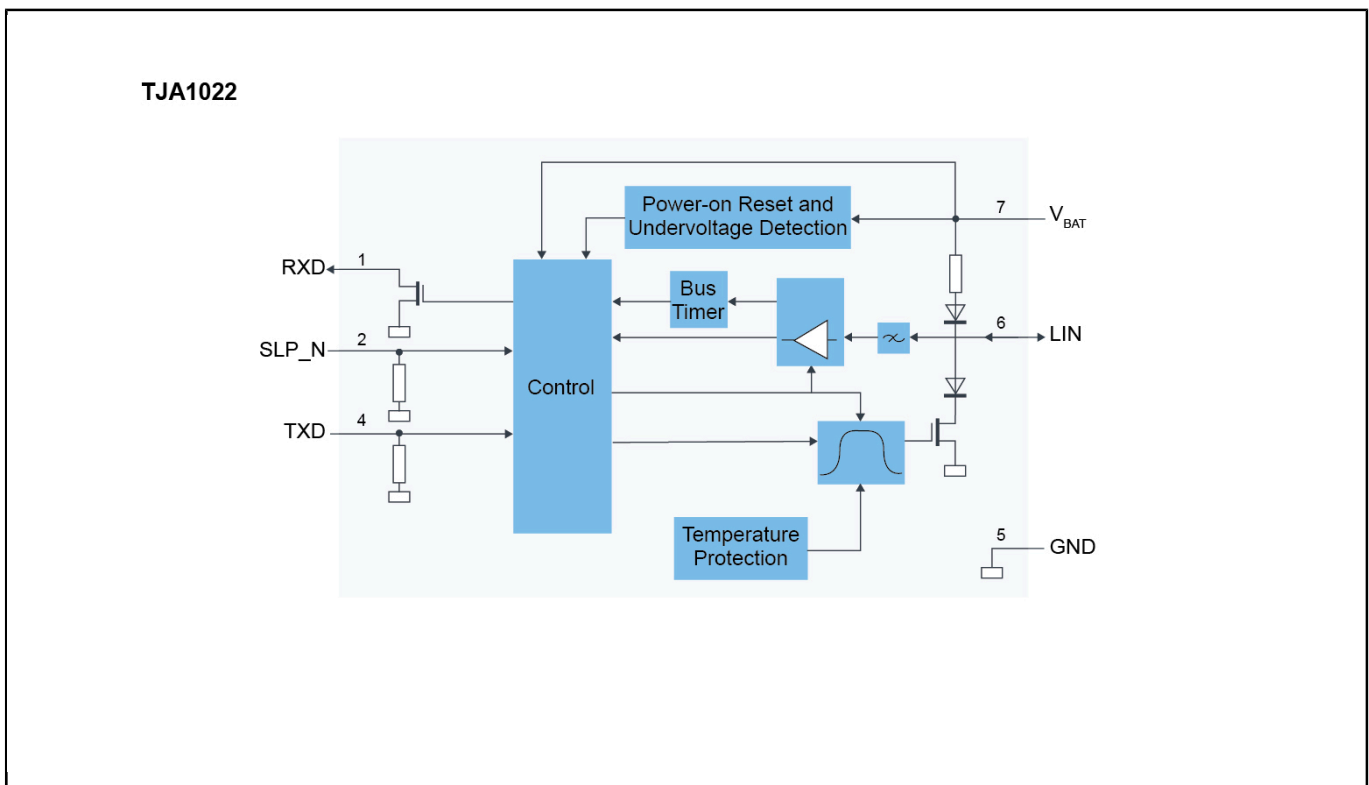

View additional information for [Dual LIN 2.2A/SAE J2602 Transceiver](#).

**Note:** The information on this document is subject to change without notice.

---

**[www.nxp.com](http://www.nxp.com)**

NXP and the NXP logo are trademarks of NXP B.V. All other product or service names are the property of their respective owners. The related technology may be protected by any or all of patents, copyrights, designs and trade secrets. All rights reserved. © 2023 NXP B.V.